

# TALL CAN OPENER

---



MODEL WST2017ZE

## **OWNER'S MANUAL**



**Westinghouse**

# **IMPORTANT SAFEGUARDS**

When using electrical appliances, basic safety precautions should always be followed including the following:

1. Read all instructions.
2. To protect against risk of electrical shock do not put cord, plugs, or appliance in water or other liquid.
3. Close supervision is necessary when any appliance is used by or near children.
4. Unplug from outlet when not in use, before putting on or taking off parts, and before cleaning.
5. Avoid contacting moving parts.
6. Do not operate any appliance with a damaged cord or plug or after the appliance malfunctions, or is dropped or damaged in any manner. Contact Consumer Service for examination, repair or electrical or mechanical adjustment.
7. The use of attachments not recommended or sold by the manufacturer may cause fire, electric shock or injury.
8. Do not use outdoors.
9. Do not let cord hang over edge of table or counter.
10. Do not let cord contact hot surface, including the stove.
11. Do not open pressurized (aerosol-type) cans.
12. Do not open cans of flammable liquids such as lighter fluids.

## **SAVE THESE INSTRUCTIONS**

**For Household Use Only**

# ADDITIONAL IMPORTANT SAFEGUARDS

1. All users of this appliance must read and understand this Owner's Manual before operating or cleaning this appliance.
2. The cord to this appliance should be plugged into a 120V AC electrical outlet only.
3. Do not leave this appliance unattended during use.
4. If this appliance begins to malfunction during use, immediately turn the unit OFF and unplug the cord. Do not use or attempt to repair the malfunctioning appliance.
5. IF this appliance falls or accidentally becomes immersed in water, unplug it immediately. **Do not reach into the water!** Do not use this appliance after it has fallen into or becomes immersed in water.
6. To reduce the risk of injury to persons or property, never use this appliance in an unstable position.
7. Do not use this appliance for other than its intended use.

## **POLARIZED PLUG**

This appliance has a polarized plug (one blade is wider than the other). To reduce the risk of electric shock, this plug is intended to fit into a polarized outlet only one way. If the plug does not fit fully in the outlet, reverse the plug. If it still does not fit, contact a qualified electrician. Do not attempt to modify the plug in any way.

## **SHORT CORD INSTRUCTIONS**

A short power-supply cord (or detachable power-supply cord) is provided to reduce the risk resulting from becoming entangled in or tripping over a longer cord.

Longer detachable power-supply cords or extension cords are available and may be used if care is exercised in their use.

If a longer detachable power-supply cord or extension cord is used, (1) the marked electrical rating of the cord set or extension cord should be at least as great as the electrical rating of the appliance, and (2) the cord should be arranged so that it will not drape over the countertop or tabletop where it can be pulled on by children or tripped over unintentionally.

## **ELECTRIC POWER**

If the electrical circuit is overloaded with other appliances, your appliance may not operate properly. It should be operated on a separate electrical circuit from other appliances.

**IMPORTANT NOTES: To ensure continued efficient performance, keep the Cutting Blade clean. Can Opener should be turned off for one minute after operating for 5 minutes.**

# GETTING TO KNOW YOUR WESTINGHOUSE WST2017ZE TALL CAN OPENER & KNIFE SHARPENER

PRODUCT MAY VARY SLIGHTLY FROM ILLUSTRATION

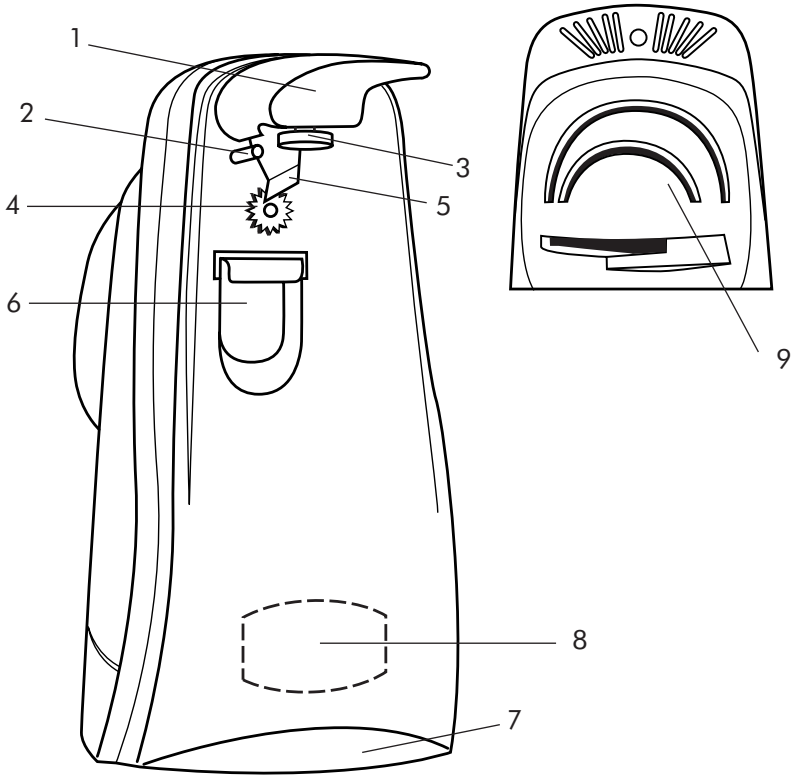

- |                                |                             |
|--------------------------------|-----------------------------|
| 1. Operating Lever (P/N 70631) | 6. Bottle Opener            |
| 2. Guide Bar                   | 7. Base                     |
| 3. Magnet                      | 8. Cord Storage             |
| 4. Geared Wheel                | 9. Knife/Scissors Sharpener |
| 5. Cutting Blade               |                             |

# BEFORE USING FOR THE FIRST TIME

1. Carefully unpack Can Opener.
2. Make sure the Can Opener is unplugged. Wipe with a soft, clean cloth or sponge. Never immerse the Can Opener in water or any other liquid.
3. Attach the Operating Lever to the Can Opener. Carefully insert the Operating Lever in the lifted position into the pivot slot and lower the Operating Lever by rotating to the right. See Figure 1.
4. Plug Can Opener into electrical outlet and press down on the Operating Lever to make sure it is operating properly.

**CAUTION: Risk of personal injury. Keep hands from beneath the Operating Lever where the Geared Wheel and Cutting Blade are located.**

**This Can Opener is designed for food contact. DO NOT use to open cans with other than food substances in them such as paint, aerosols, etc.**

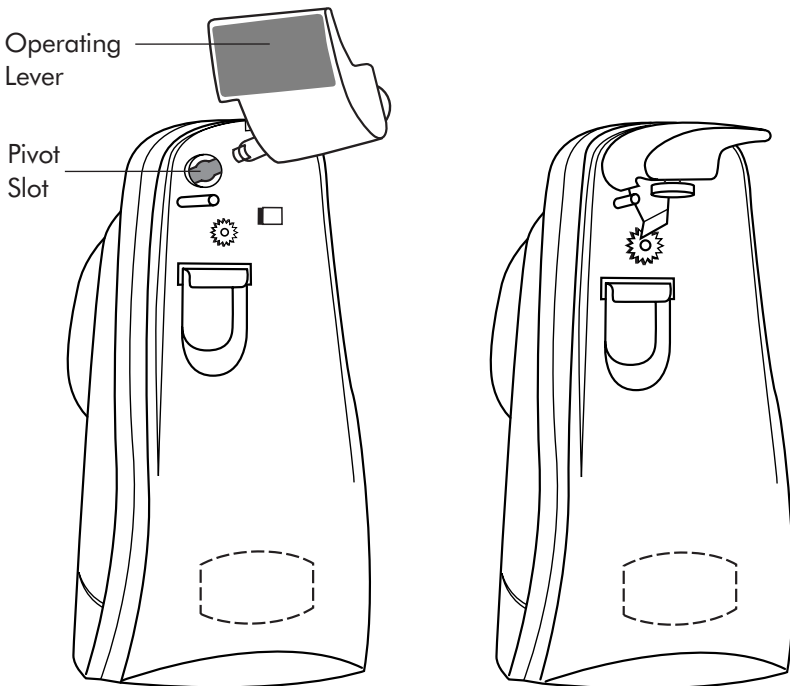

**Figure 1**

# OPERATING INSTRUCTIONS

## TO USE CAN OPENER

1. Place Can Opener on level surface.
2. Plug the Can Opener into a 120V AC electrical outlet.
3. Raise the Operating Lever, place can beneath the Guide Bar and against the Geared Wheel.
4. Press down on Operating Lever to pierce lid of can. This automatically starts the cutting action. Lightly support the can while it is being opened. The Can Opener will continue to cut until the Lid is completely severed from the can.
5. Grasp the can, then raise the Operating Lever to release the can.
6. Carefully remove lid from the Magnet. **USE CAUTION TO AVOID INJURY FROM EDGE OF LID.**

## TO USE KNIFE SHARPENER

1. Place Can Opener on level surface.
2. Plug the Can Opener into a 120V AC electrical outlet.
3. Turn the unit around so that the Knife/Scissors sharpening slots are facing you.
4. Select the appropriate sharpening slot. The upper vertical slot is for sharpening the front edge of the knife blade and the lower vertical slot is for sharpening the back edge of the knife blade.
5. Press down and hold the Operating Lever. Insert the blade into the slot and slowly draw the blade to the right with a slow, even motion, as shown in Figure 2. Alternate from one sharpening slot to the other until desired sharpness is achieved.

**NOTE:** Blades to be sharpened should be clean. Do not sharpen knives that have serrated blades.

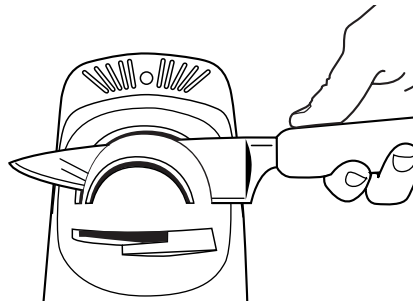
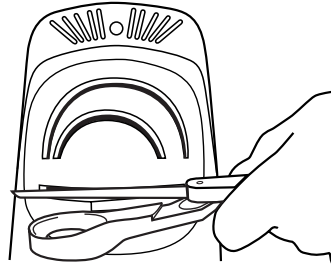

**Figure 2**

# OPERATING INSTRUCTIONS (Cont.)

## TO USE SCISSORS SHARPENER

1. Place Can Opener on level surface.
2. Plug the Can Opener into a 120V AC electrical outlet.
3. Turn the unit around so that the Knife/Scissors sharpening slots are facing you. The horizontal sharpening slot is designed especially for scissors.
4. Press down and hold the Operating Lever. Place one blade of the scissors in the groove and slowly draw the blade to the right with a slow, even motion. Repeat with the other blade.

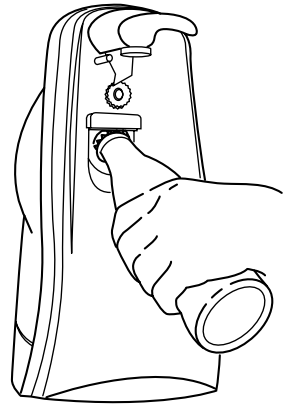

**Figure 3**

## TO USE BOTTLE OPENER

1. Unplug appliance from electrical socket.
2. Place Can Opener on a level Surface. To steady, position one hand on top of the Can Opener.
3. Place bottle cap edge under Opener Flange.
4. Apply downward pressure on bottle until cap pops off.

**NOTE:** This bottle opener is not recommended for bottles having "Twist-Off" caps.



**Figure 4**



# USER MAINTENANCE INSTRUCTIONS

This Westinghouse WST2017ZE Can Opener requires little maintenance. It contains no user-serviceable parts. Any servicing requiring disassembly other than instructed below must be performed by a qualified appliance repair technician.

**CAUTION: Always unplug Can Opener from electrical outlet when not in use and before cleaning. Never immerse Can Opener, cord or plug in water or any other liquid.**

## CARE AND CLEANING

The Can Opener should be kept clean to avoid food contamination.

1. Unplug Can Opener.
2. To remove the Operating Lever hold the Can Opener facing you and lift the Operating Lever upward, then gently pull toward you.  
**Exercise caution when removing, washing and replacing the Operating Lever; Cutting Blade is sharp and can cause injury.**
3. Wash the Operating Lever in warm soapy water. To remove stubborn food spots, dab a small amount of dishwashing liquid onto a small brush and gently scrub clean. Rinse well and allow to dry thoroughly before replacing it on the unit.
4. If necessary, wipe exterior surface of Can Opener with a soft, slightly damp cloth or sponge. **Do not allow water, or any other liquid, to get into the unit.**  
**CAUTION: Do not use scouring pads or any type of harsh cleanser that may damage the surfaces or dull the Cutting Blade.**
5. Reattach the Operating Lever to the Can Opener. Carefully insert the Operating Lever in the lifted position into the pivot slot and lower the Operating Lever by rotating to the right.

## TO STORE

1. Unplug the Can Opener and clean as instructed above.
2. Make sure all parts are dry and store appliance in its original box or in a clean, dry location.
3. Never store with cord plugged in. Do not wrap cord tightly around the appliance. Return cord to cord storage compartment.

## LIMITED ONE-YEAR WARRANTY

**Warranty Coverage:** This product is warranted to be free from defects in materials or workmanship for a period of one (1) year from the original purchase date. This product warranty is extended only to the original consumer purchaser of the product and is not transferable. For a period of one (1) year from the date of original purchase of the product, our Repair Center will, at its option, either (1) repair the product or (2) replace the product with a reconditioned comparable model. These remedies are the purchaser's exclusive remedies under this warranty.

**Warranty Service:** To obtain warranty service, you must call our warranty service number at 1-800-233-9054 for return instructions on how to deliver the product, in either the original packaging or packaging affording an equal degree of protection to the Repair Center specified below. You must enclose a copy of your sales receipt or other proof of purchase to demonstrate eligibility for warranty coverage.

**To return the appliance, ship to:**  
ATTN: Repair Center  
708 South Missouri Street  
Macon, MO 63552 USA

**To contact us, please write to, call, or email:**  
Consumer Relations Department  
PO Box 7366  
Columbia MO 65205-7366 USA  
1-800-233-9054  
E-mail:  
consumer\_relations@toastmaster.com

**What Is Not Covered:** This warranty does not cover damage resulting from misuse, accident, commercial use, improper service or any other damage caused by anything other than defects in material or workmanship during ordinary consumer use. This warranty is invalid if the serial number has been altered or removed from the product. This warranty is valid only in the United States and Canada.

**LIMITATION ON DAMAGES:** THERE SHALL BE NO LIABILITY FOR ANY INCIDENTAL OR CONSEQUENTIAL DAMAGES FOR BREACH OF ANY EXPRESS OR IMPLIED WARRANTY OR CONDITION ON THIS PRODUCT.

**DURATION OF IMPLIED WARRANTIES:** EXCEPT TO THE EXTENT PROHIBITED BY APPLICABLE LAW, ALL IMPLIED WARRANTIES AND CONDITIONS, INCLUDING, WITHOUT LIMITATION, IMPLIED WARRANTIES AND CONDITIONS OF MERCHANTABILITY AND FITNESS FOR A PARTICULAR PURPOSE OR USE ON THIS PRODUCT ARE LIMITED IN DURATION TO THE DURATION OF THIS WARRANTY.

Some jurisdictions do not allow the exclusion or limitation of incidental or consequential damages, or allow limitations on how long an implied warranty lasts, so the above limitations or exclusions may not apply to you. This warranty gives you specific legal rights and you may have other rights under the laws of your jurisdiction.

For more information on our products, visit our website: [www.maxim-toastmaster.com](http://www.maxim-toastmaster.com).